

HAYRITE HAY CONVEYOR (Model HEC)

KEY NO.	DESCRIPTION	OLD PART NO.	NEW PART NO.
1	NUT,NY-IN LOCK,5/16-18,G2,PLT	HEC-00001	F356040
2	CLAMP,EHD/HEC ELEV MOTOR MOUNT	HEC-00002	70500
3	PIPE,HEC BALE ELEV MOTOR MOUNT	HEC-00003	HEC-00003
4	HHCS,5/16-18 X 3",G5,PLT	HEC-00004	F1072375
5	BEARING W/STRAIGHT ZK,FLANGE,1"ID	HEC-00005	FAH16G
6	WASHER,SPRING LOCK,5/16",PLT	HEC-00006	F805050
7	NUT,HEX,5/16-18,G5,PLT	HEC-00007	F354040
9	BUSHING,MACH,18 X 1-1/32 X 1-1/2",UPLT	HEC-00009	F806060
10	SPROCKET,HEC,#55 X 7T X 1"ID	HEC-000010	HEC-000010
11	PIN,ROLL,5/16 X 1-7/8",PLT	HEC-000011	F407055
13	PIN,ROLL,5/16 X 1-1/2",PLT	HEC-000013	F407050
14	WASHER,STD FL,5/16",PLT	HEC-000014	F808030
15	TIGHTENER,NYLON ROLLER CHAIN	HEC-000015	70449
16	HHCS,5/16-18 X 1-3/4",G5,PLT	HEC-000016	F1072357
17	NUT,HEX,3/8-16,G5,PLT	HEC-000017	F354050
18	WASHER,SPRING LOCK,3/8",PLT	HEC-000018	F805060
19	HHCS,3/8-16 X 1",G5,PLT	HEC-000019	F1072450
20	FRAME W/SHAFT & SPROCKET,DRIVE,8'	HEC-000020	70420
21	ARM,ELEV MOTOR MOUNT ADJUSTING	HEC-000021	70431
22	HHCS,5/16-18 X 1",G5,PLT	HEC-000022	F1072345
23	SS,SK-HD,K-P5/16-18 X 3/8",G2,UPLT	HEC-000023	F702037
24	V-BELT,TYPE A,4L450	HEC-000024	4L450
25	PULLEY,12" X 1"BORE	HEC-000025	70519
26	SPROCKET W/SHAFT,HEC,#40 X 12T X 1"	HEC-000026	HEC-000026
27	LINK W/PIN&CLIP,ROLL CHAIN,#40	HEC-000027	N0401
28	CHAIN W/LINK,ROLLER,#40 X 62 PITCH	HEC-000028	70016
29	SPROCKET W/SHAFT,HEC,#40 X 50T X 1"	HEC-000029	HEC-000029
30	TUBE,RD,DOM,11/64" X 1-3/8" X 1/2"L	HEC-000030	70976
31	HHCS,5/16-18 X 3/4",G5,PLT	HEC-000031	F1072340
32	NUT,WING,3/8-16,G2,PLT	HEC-000032	F358080
33	COVER W/DECALS,HEC/EHD SHIELD	HEC-000033	70448
34	NUT,NY-IN LOCK,1/4-20,G2,PLT	HEC-000034	F356030
35	HHCS,1/4-20 X 1-1/2",G5,PLT	HEC-000035	F1072255
36	SHIELD,HEC FRAME(UPPER)	HEC-000036	HEC-000036
37	SHIELD,HEC/EHD FRAME(LOWER)	HEC-000037	70447
38	HHCS,1/4-20 X 3/4",G5,PLT	HEC-000038	F1072245
39	SHAFT,HEC BALE ELEVATOR IDLER	HEC-000039	HEC-000039
40	HH TAP BOLT,3/8-16 X 3-1/2",G2,PLT	HEC-000040	F108555
41	PIPE,PLASTIC,3/4" X 5/8"L	HEC-000041	HEC-000041
42	SPROCKET,CAST IDLER, #55 X 6-TOOTH X .755"	INCLUDED IN KEY NO. 55	
42A	SPROCKET,W/BEARING #55 X 6T X .772	HEC-000042	AG2426-F
43	CHAIN W/RAISED LINK,BALE,#55,1'	HEC-000043	HC551
44	LINK,BALE ELEV #55 RAISED	HEC-000044	HB4-55
45	IDLER L/PARTS BOX,HEC ELEV,8'	HEC-000045	HEC-8I-LPB
46	DECAL,WARNING-BEFORE STARTING	HEC-000046	11096
48	DECAL,DANGER-SHIELDS ARE OFF	HEC-000048	11097
49	RETURN,BALE ELEV #55 CHAIN	HEC-000049	HEC-000049
50	U-BOLT,5/16-18 X 1-3/8 X 2-3/16",G2	HEC-000050	F105020
51	BUSHING,MACH,18 X 24/32 X 1-1/4",UPLT	HEC-000051	F806030
52	PIPE,PLASTIC,3/4" X 1-17/32" (POST 4/15/05)	N/A	71014
53	MANUAL ASSY,HEC BALE ELEV OWNER	HEC-000053	HEC-000053
54	DECAL,DANGER-FALLING HAY...	HEC-000054	DEC101293
55	SPROCKET W/SPACER & BUSHINGS,#55 X 6-TOOTH X .755"	N/A	71013

* Specify serial number of elevator

ILLUSTRATION A

DRIVE END

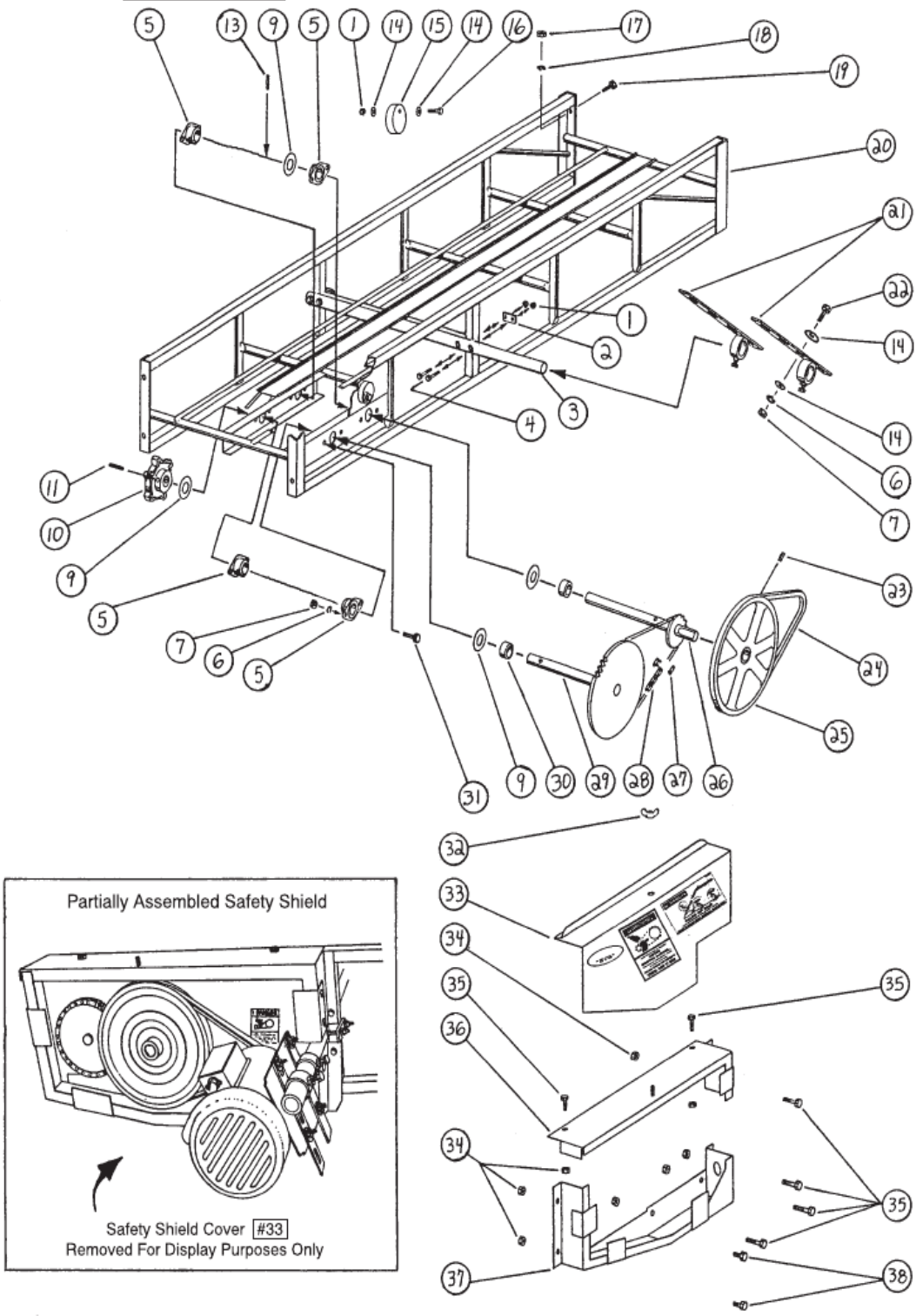

53

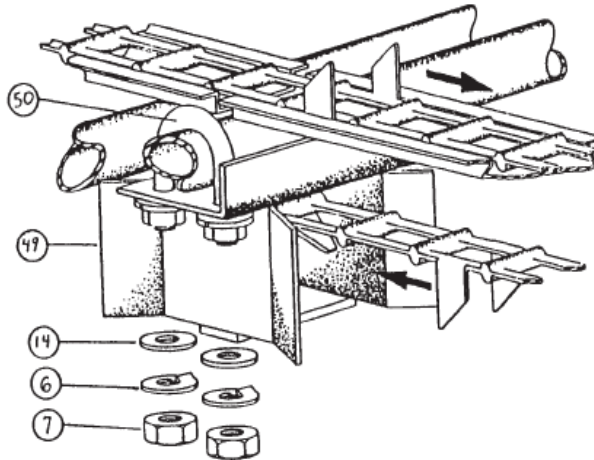
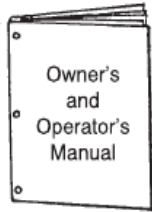

IDLER SECTION

Illustration B

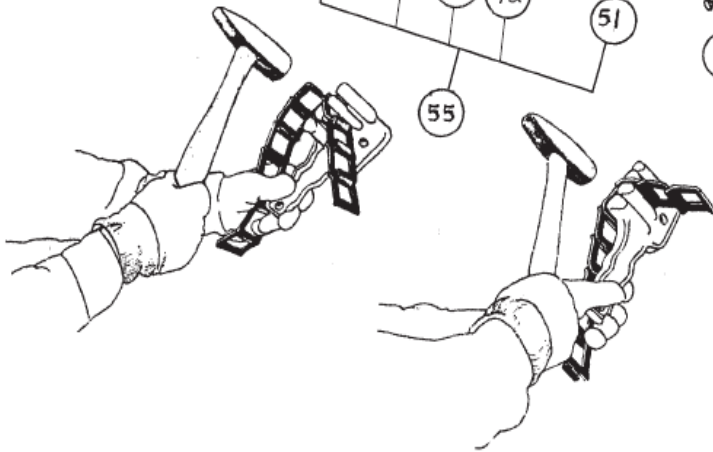
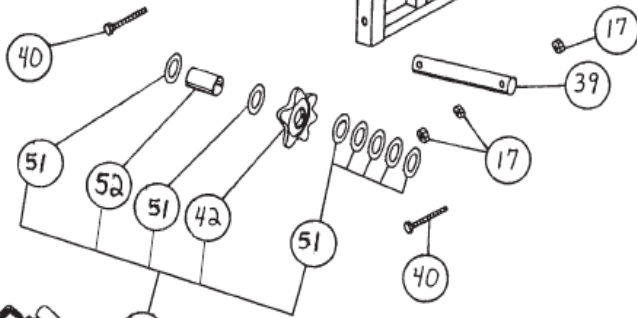
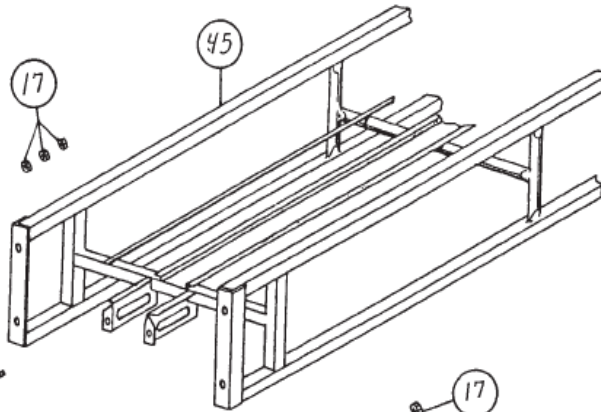
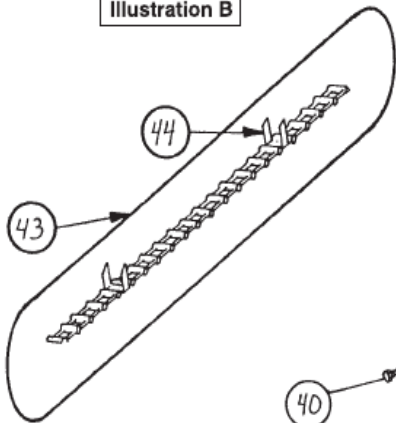

The Decals Shown On This Page Must Be Displayed As Shown Below

FREE REPLACEMENTS ARE AVAILABLE UPON REQUEST

- Safety decals must be replaced if they are destroyed, missing, painted over, or can no longer be read.
- New equipment components installed during repair shall be equipped with the same safety decals that were affixed to the original components.
- Keep decals wiped clean at all times.

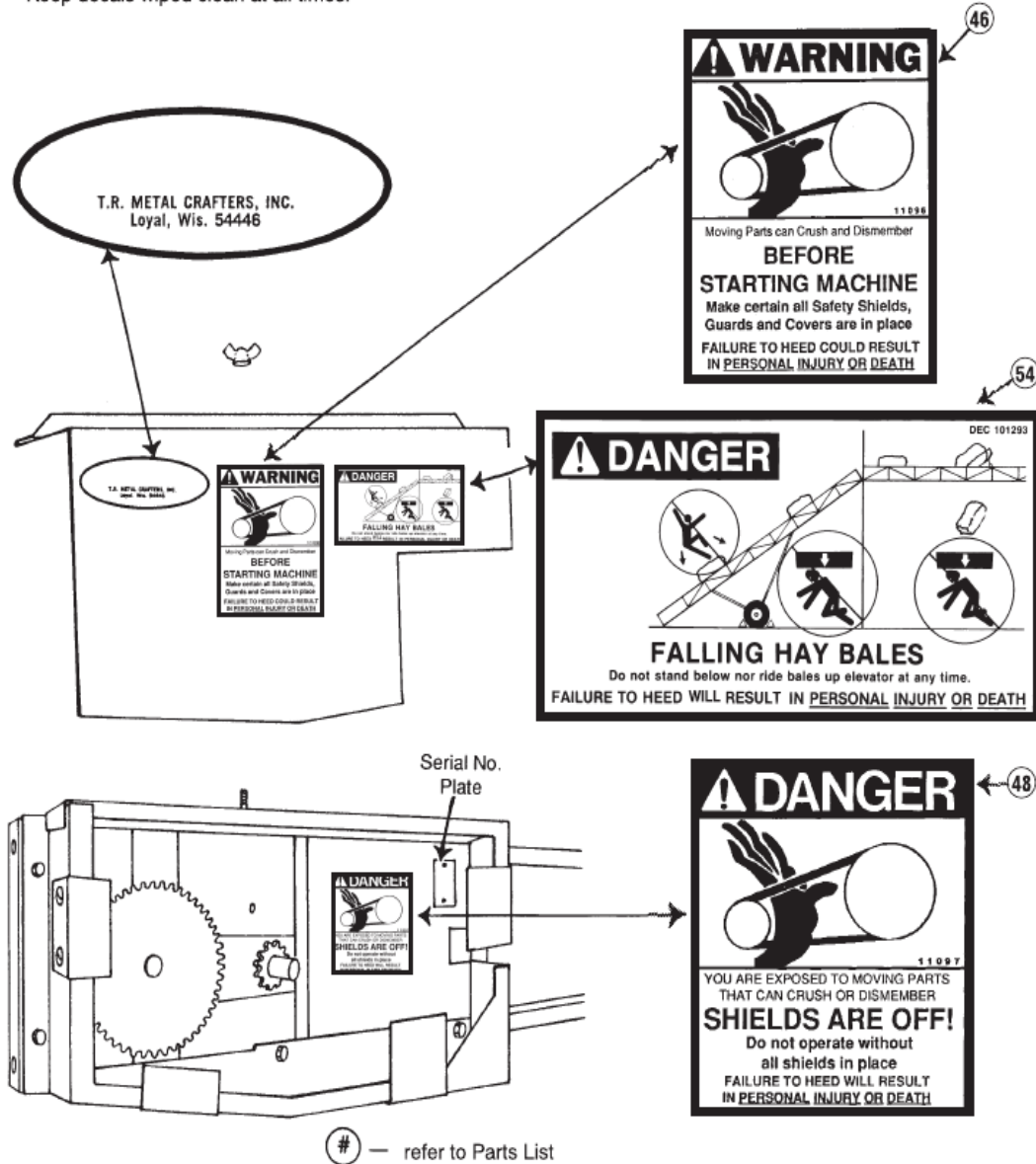
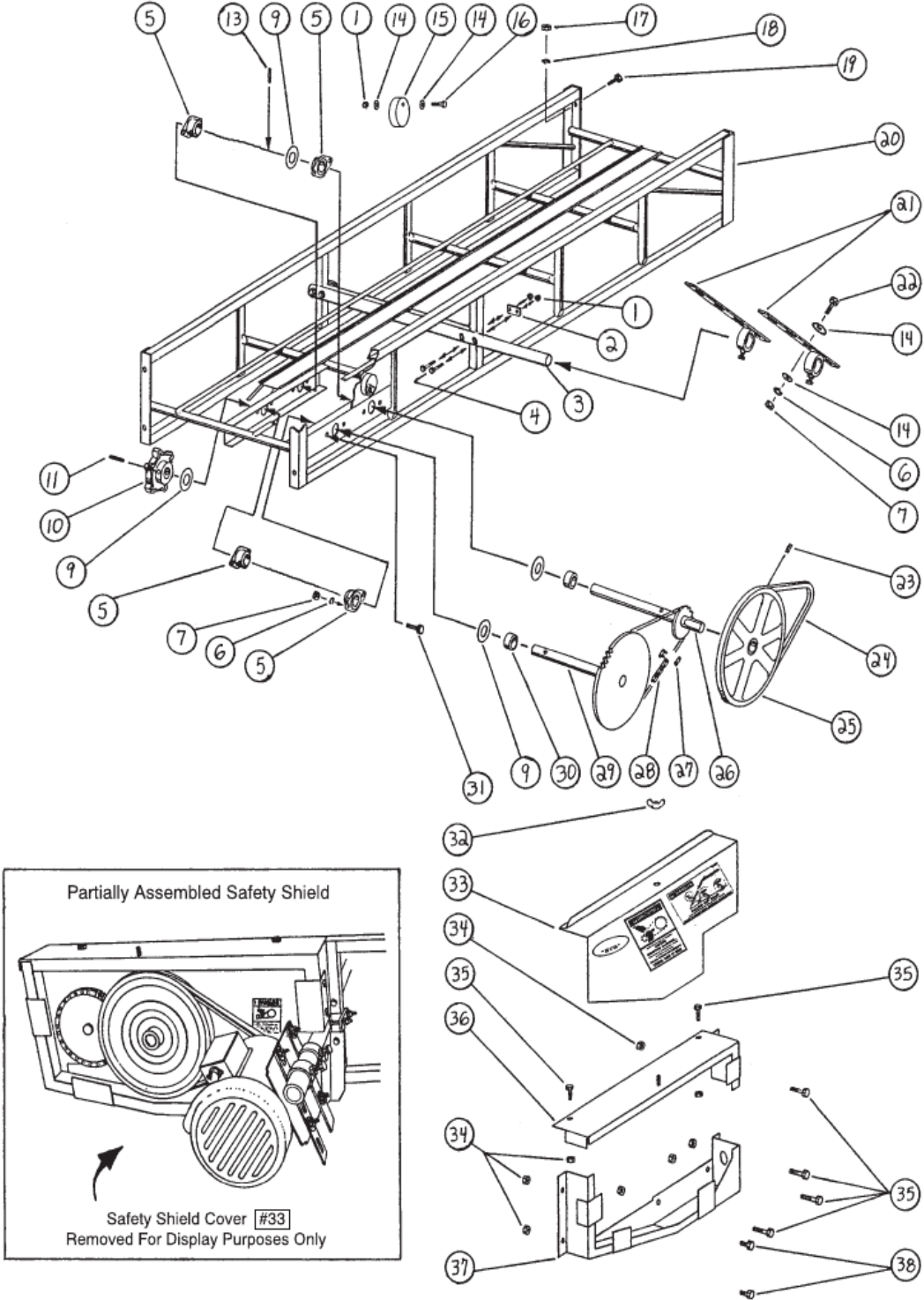
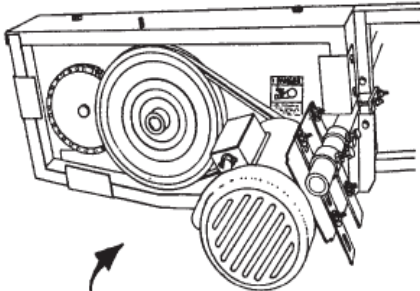

ILLUSTRATION A

DRIVE END



Partially Assembled Safety Shield



Safety Shield Cover #33
Removed For Display Purposes Only

The Decals Shown On This Page Must Be Displayed As Shown Below

FREE REPLACEMENTS ARE AVAILABLE UPON REQUEST

- Safety decals must be replaced if they are destroyed, missing, painted over, or can no longer be read.
- New equipment components installed during repair shall be equipped with the same safety decals that were affixed to the original components.
- Keep decals wiped clean at all times.

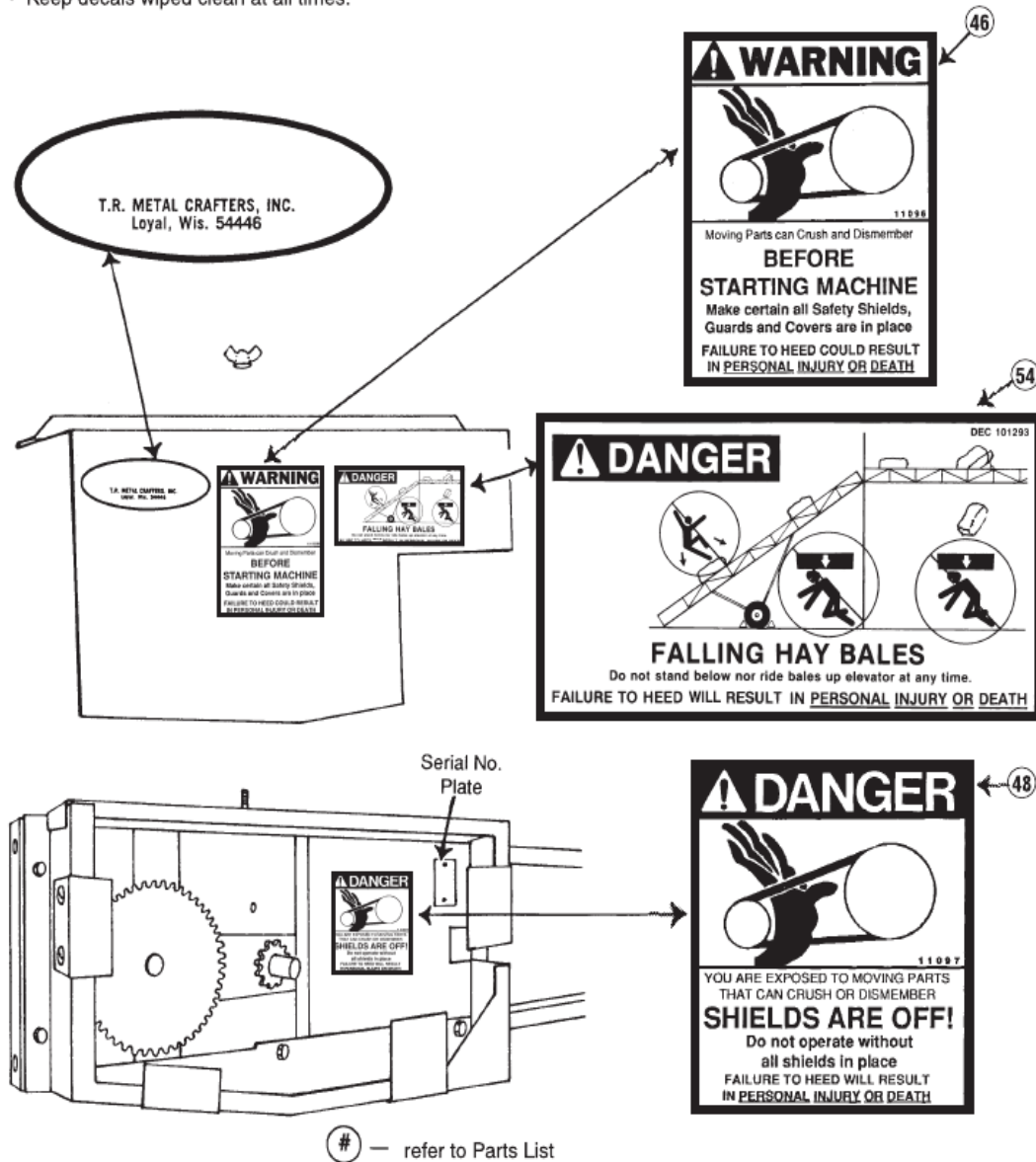

HAYRITE HAY CONVEYOR TRANSPORT

KEY NO.	DESCRIPTION	Model No. HST-10T		Model No. HST-20T		Model No. HST-40T	
		OLD PART NO.	NEW PART NO.	OLD PART NO.	NEW PART NO.	OLD PART NO.	NEW PART NO.
1	BOLT,WHEEL,1/2-20 X 1-3/4",UNF	10T1	13884	20T1	13884	40T1	13884
2	RIM,WHEEL,15 X 5 X 4-BOLT,.375	10T2	10T2	20T2	10T2	40T2	10T2
3	CAP,DUST,15/16" OAL	10T3	13880	20T3	13880	40T3	13880
4	PIN, COTTER,5/32 X 1",PLT	10T4	F403040	20T4	F403040	140T4	F403040
5	NUT,BALE TRAN WHEEL HUB CASTLE	10T5	10T5	20T5	10T5	40T5	10T5
6	CONE, BEARING, 3/4", LM11949	10T6	13881	20T6	13881	40T6	13881
6A	CONE, BEARING, 1-1/4", LM67048	10T6A	13882	20T6A	13882	40T6A	13882
7	HUB,TRANSPORT,4 BOLT	10T7	13885	20T7	13885	40T7	13885
8	SEAL,GREASE,1.9375" X 2.3125"	10T8	13883	20T8	13883	40T8	13883
9	AXLE,BALE ELEV TRANSPORT	10T9	70537	20T9	70537	40T9	70537
10	HHCS,3/8-16 X 1",G5,PLT	10T10	F1072450	20T10	F1072450	40T10	F1072450
11	WASHER,SPRING LOCK,3/8",PLT	10T11	F805060	20T11	F805060	40T11	F805060
12	NUT,HEX,3/8-16,G5,PLT	10T12	F354050	20T12	F354050	40T12	F354050
13	LEG,10T TRANSPT,9' LONG,3-DOTS	10T13	10T13	—	—	—	—
13	LEG,20T TRANSPT,15' LONG,3-DOTS	—	—	20T13	20T13	—	—
13	LEG,40T TRANSPT,20' LONG,3-DOTS	—	—	—	—	40T13	40T13
14	CLAMP,WIRE ROPE CABLE,1/4",PLT	10T14	70042	20T14	70042	40T14	70042
15	FRAME, TRANS ROLLER END	10T15	70578	20T15	70558	40T15	70558
16	PIN,BALE ELEV TRANS ROLLER	10T16	70555	20T16	70555	40T16	70555
17	ROLLER,BALE TRANSPORT	10T17	10T17	20T17	10T17	40T17	10T17
18	PIN,HAIR,.120 X 2-3/8",PLT	10T18	F405063	20T18	F405063	40T18	F405063
19	NUT,NY-IN LOCK,1/2-13,G2,PLT	10T19	F356060	20T19	F356060	40T19	F356060
20	HHCS,1/2-13 X 1-1/4", G5,PLT	10T20	F1072643	20T20	F1072643	40T20	F1072643
21	BRACE,TRANSPORT,1/8"X1"X1"X 80"	10T21	70546	20T21	70546	40T21	70546
22	CABLE,GAC FU CT, 7/19X1/4"X39'	10T22	70109	—	—	—	—
22	CABLE,GAC FU CT, 7/19x1/4"X93'	—	—	20T22	70108	—	—
22	CABLE,GAC FU CT, 7/19X1/4"X124'	—	—	—	—	40T22	70107
23	LEG,10T TRANS,9' LONG,4-DOTS	10T23	10T23	—	—	—	—
23	LEG,20T TRANS,15' LONG,4-DOTS	—	—	20T23	20T23	—	—
23	LEG,40T TRANS,20' LONG,4-DOTS	—	—	—	—	40T23	40T23
24	HHCS,1/2-13 X 2",G5,PLT	10T24	F1072655	20T24	F1072655	40T24	F1072655
25	THIMBLE,WIRE ROPE,CLOSED,1/4"	10T25	43443	20T25	43443	40T25	43443
26	HOLDER,TRANS PULLEY,1/4"X2"X8"	10T26	70556	20T26	70556	40T26	70556
27	PULLEY W/BUSH,WRP,1/2"IDX 3"OD	10T27	13834	20T27	13834	40T27	13834
28	PIN,ROLL,5/16 X 3", PLT	10T28	F407085	20T28	F407085	40T28	F407085
29	LEG,10T TRANS,9' LONG,2-DOTS	10T29	10T29	—	—	—	—
29	LEG,20T TRANS,15' LONG,2-DOTS	—	—	20T29	20T29	—	—
29	LEG,40T TRANS,20' LONG,2-DOTS	—	—	—	—	40T29	40T29
30	HHCS,3/8-16 X 2-1/4", G5,PLT	10T30	F1072483	20T30	F1072483	40T30	F1072483
31	ARM,BALE ELEV TRANS PIVOT	10T31	70568	20T31	70568	40T31	70568
32	BRACKET,PIVOT ARM,1/4"X2" X 3"	10T32	70569	20T32	70569	40T32	70569

Continued on next page.

KEY NO.	DESCRIPTION	Model No. HST-10T		Model No. HST-20T		Model No. HST-40T	
		OLD PART NO.	NEW PART NO.	OLD PART NO.	NEW PART NO.	OLD PART NO.	NEW PART NO.
33	NUT,NY-IN LOCK,3/8-16,G2,PLT	10T33	F356050	20T33	F356050	40T33	F356050
34	FRAME, TRANS PIVOT END	10T34	70579	20T34	70564	40T34	70564
35	HOLDER,TRANS PULLEY,1/4"X2"X5"	10T35	70563	20T35	70563	40T35	70563
36	WINCH W/DECAL PLATE,1500 IB	10T36	70951	20T36	70951	40T36	70951
37	LEG,10T TRANS,9' LONG,1-DOT	10T37	10T37	—	—	—	—
37	LEG,20T TRANS,15' LONG,1-DOT	—	—	20T37	20T37	—	—
37	LEG,40T TRANS,20' LONG,1-DOT	—	—	—	—	40T37	40T37
38	FLAT,HR,1/4" X 6" X 5"L-PUNCH	10T38	70543	20T38	70543	40T38	70543
40	CABLE,SAFETY,1/4" X 15'8"	10T40	10T40	—	—	—	—
40	CABLE,SAFETY,3/8" X 27'11"	—	—	20T40	20T40	—	—
40	CABLE,SAFETY,1/2" X 38'1-1/2"	—	—	—	—	40T40	40T40
41	CABLE,GAC FU CT,7/19X1/8"X2'	10T41	70110	20T41	70110	40T41	70110
42	MANUAL ASSY,BALE TRANSPORT	10T42	YA12172	20T42	YA12172	40T42	YA12172
43	DECAL,TRANSPORT ELECTROC	10T43	DEC1101-DANGR	20T43	DEC1101-DANGR	40T43	DEC1101-DANGR
44	DECAL,WARNING-BALE TRANS	10T44	DEC1101-WARNG	20T44	DEC1101-WARNG	40T44	DEC1101-WARNG
45	CLAMP,WIRE ROPE CABLE,1/8",PLT	10T45	70043	20T45	70043	40T45	70043
46	NUT,TOP-LOCK,3/4-10,G8,PLT	10T46	F355350	20T46	F355350	40T46	F355350
47	HHCS,3/4-10 X 2",G8,PLT	10T47	F107360	20T47	F107360	40T47	F107360

* Specify serial number of elevator

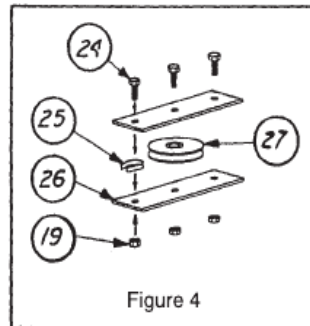
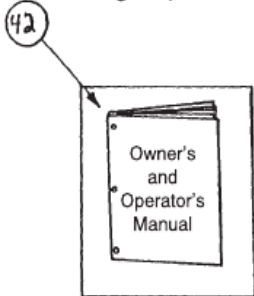
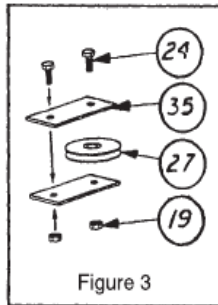
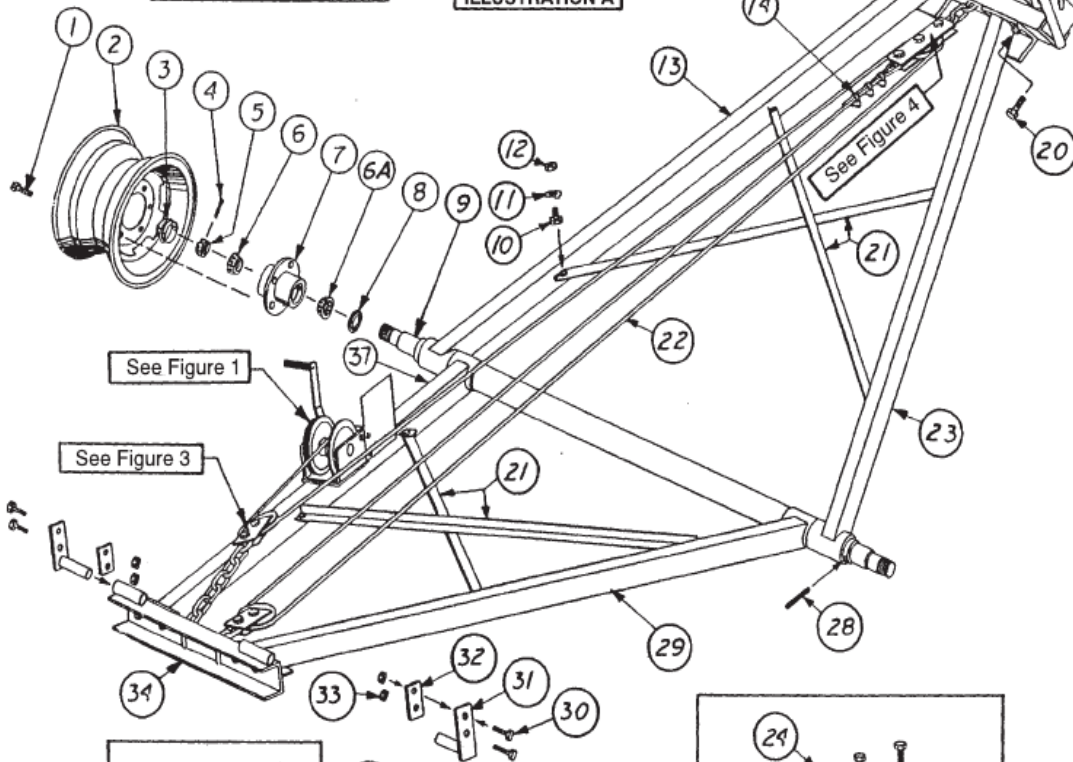
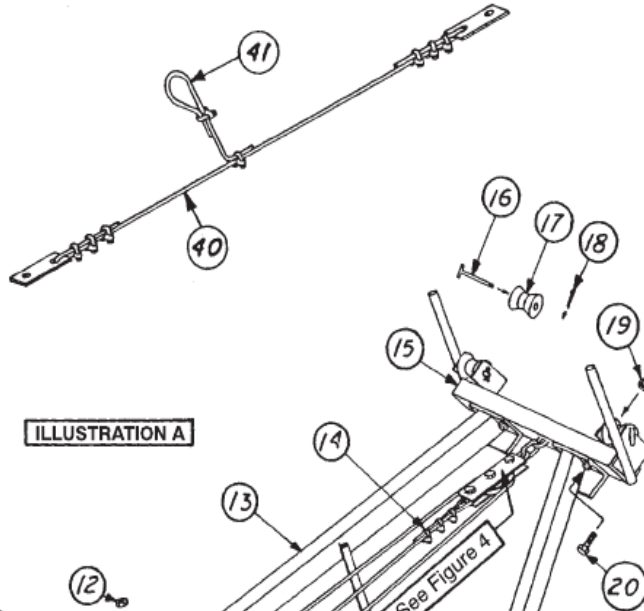
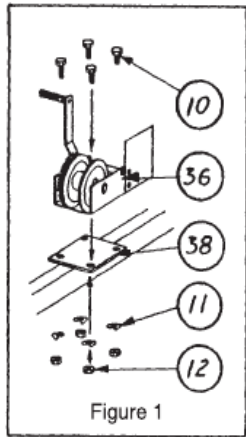

The Decals Shown On This Page Must Be Displayed As Shown Below

FREE REPLACEMENTS ARE AVAILABLE UPON REQUEST

- Safety decals must be replaced if they are destroyed, missing, painted over, or can no longer be read.
- New equipment components installed during repair shall be equipped with the same safety decals that were affixed to the original components.
- Keep decals wiped clean at all times.

DEC1101-DANGR



⚠ DANGER
THIS MACHINE IS NOT GROUNDED
ELECTROCUTION HAZARD

Keep at least 10 feet away from overhead electrical wires and devices. Electrocution can occur without direct contact. Measure overall transport height and check for adequate clearance before moving transport.

FAILURE TO HEED WILL RESULT IN SEVERE SHOCK OR DEATH

DEC1101-DANGR

43

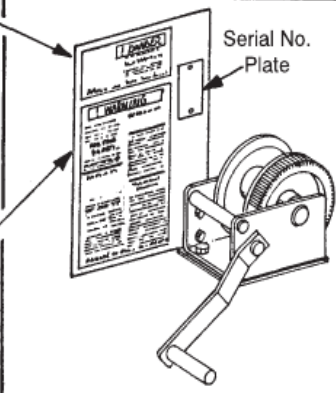

Serial No. Plate

DEC1101-WARNG

⚠ WARNING

AN ELEVATOR TRANSPORT CAN BE HAZARDOUS IN THE HANDS OF AN UNFAMILIAR, UNTRAINED OR CARELESS OPERATOR

FOR YOUR SAFETY...

Do not operate, service, inspect or otherwise handle this unit without reading the Owner's and Operator's Manual completely and being familiar with the operation of this machine. If the Owner's and Operator's Manual is missing, contact T. R. Metal Crafters, Inc., 312 E. Industrial Drive, P. O. Box 248, Loyal, WI 54446. (Phone 715/235-8518).

MOUNTING ELEVATOR



Discharge End

Safety Cable

Do not mount a longer or shorter length elevator than recommended below on transport. Failure to heed may result in personal injury or death.

Model HST-18T	Fits only MaxPro elevators 30' through 32' long
Model HST-20T	Fits only MaxPro elevators 30' through 48' long
Model HST-40T	Fits only MaxPro elevators 34' through 60' long

Make sure the safety cable is installed onto transport at the correct location. Refer to Owner's and Operator's Manual for instructions. The safety cable prevents transport from being lowered to an unsafe working position. Failure to install safety cable may result in personal injury or death. Note: Elevator weight should never rest on transport safety cable during normal operation. If safety cable is lost or missing, contact T.R. Metal Crafters, Inc. for free replacement.

FAILURE TO HEED COULD RESULT IN PERSONAL INJURY OR DEATH

3001101-WARNG

44

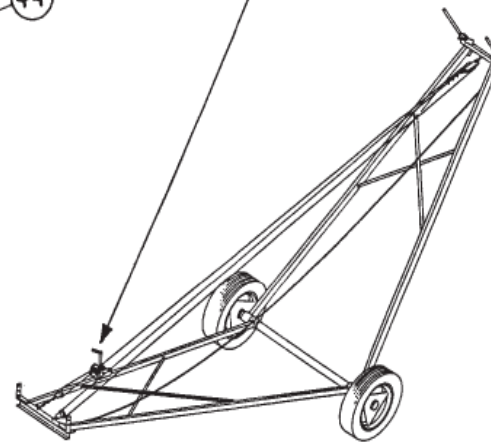

WHEN RAISING OR LOWERING



FALLING ELEVATOR CAN INJURE AND KILL

1. Read and follow labels on winch.
2. Make sure transport is on firm, level ground.
3. Never permit anyone to stand on or under the elevator.
4. Never stand alongside winch cable. If cable breaks, it can act like a deadly whip.
5. Always inspect the cable and clamps for damage prior to each use.
6. Never continue turning handle counterclockwise if elevator does not lower - elevator may release and drop suddenly. Return elevator to full raised position if possible. Securely support elevator to prevent it from dropping before repairing cable or transport mechanism.
7. After lowering, turn handle clockwise two clicks to lock brake.

TRANSPORTING AND POSITIONING

1. Elevator must be empty and in recommended down position before moving.
2. Lower elevator at least 10 feet below level of power lines before moving. Use a locking hitch pin.
3. Transports are designed ONLY for towing at tractor speeds up to 20 mph between sunrise and sunset. Check and comply with all state and local regulations governing marking, lighting, towing and maximum width.
4. Do not allow anyone to ride on the elevator when transporting or operating.
5. Leave elevator in down position until final positioning requires raising it.
6. Block wheels and secure discharge and to bin or building or anchor intake and to prevent rolling or spreading.

HAYRITE HAY CONVEYOR (Model EHD)

KEY NO.	DESCRIPTION	OLD PART NO.	NEW PART NO.
1	NUT,NY-IN LOCK,5/16-18,G2,PLT	EHD-00001	F356040
2	CLAMPEHD/HEC ELEV MOTOR MOUNT	EHD-00002	70500
3	PIPE,EHD BALE ELEV MOTOR MOUNT	EHD-00003	EHD-00003
4	HHCS,5/16-18 X 3",G5,PLT	EHD-00004	F1072375
5	BEARING W/STRAIGHT ZK,FLANGE,1"ID	EHD-00005	FAH16G
6	WASHER,SPRING LOCK,5/16",PLT	EHD-00006	F805050
7	NUT,HEX,5/16-18,G5,PLT	EHD-00007	F354040
9	BUSHING,MACH,18 X 1-1/32 X 1-1/2",UPLT	EHD-00009	F806060
10	SPROCKET,EHD,#62 X 7T X 1"ID	EHD-00010	EHD-00010
11	PIN,ROLL,5/16 X 1-7/8",PLT	EHD-00011	F407055
13	PIN,ROLL,5/16 X 1-1/2",PLT	EHD-00013	F407050
14	WASHER,STD FL,5/16",PLT	EHD-00014	F808030
15	TIGHTENER,NYLON ROLLER CHAIN	EHD-00015	70449
16	HHCS,5/16-18 X 1-3/4",G5,PLT	EHD-00016	F1072357
17	NUT,HEX,3/8-16,G5,PLT	EHD-00017	F354050
18	WASHER,SPRING LOCK,3/8",PLT	EHD-00018	F805060
19	HHCS,3/8-16 X 1",G5,PLT	EHD-00019	F1072450
20	FRAME W/SHAFT & SPROCKET,DRIVE,6'	EHD-00020	70516
21	ARM,ELEV MOTOR MOUNT ADJUSTING	EHD-00021	70431
22	HHCS,5/16-18 X 1",G5,PLT	EHD-00022	F1072345
23	SS,SK-HD,K-P5/16-18 X 3/8",G2,UPLT	EHD-00023	F702037
24	V-BELT,TYPE AX43,NOTCHED EDGE	EHD-00024	AX43
25	PULLEY,12" X 1"BORE	EHD-00025	70519
26	SPROCKET W/SHAFT,EHD,#40 X 12T X 1"	EHD-00026	EHD-00026
27	LINK W/PIN&CLIP,ROLL CHAIN,#40	EHD-00027	N0401
28	CHAIN W/LINK,ROLLER,#40 X 62 PITCH	EHD-00028	70016
29	SPROCKET W/SHAFT,EHD,#40 X 50T X 1"	EHD-00029	EHD-00029
30	TUBE,RD,DOM,11/64" X 1-3/8" X 1/2"L	EHD-00030	70976
31	HHCS,5/16-18 X 3/4",G5,PLT	EHD-00031	F1072340
32	NUT,WING,3/8-16,G2,PLT	EHD-00032	F358080
33	COVER W/DECALS,HEC/EHD SHIELD	EHD-00033	70448
34	NUT,NY-IN LOCK,1/4-20,G2,PLT	EHD-00034	F356030
35	HHCS,1/4-20 X 1-1/2",G5,PLT	EHD-00035	F1072255
36	SHIELD,EHD FRAME(UPPER)	EHD-00036	EHD-00036
37	SHIELD,HEC/EHD FRAME(LOWER)	EHD-00037	70447
38	HHCS,1/4-20 X 3/4",G5,PLT	EHD-00038	F1072245
39	SHAFT,EHD BALE ELEVATOR IDLER	EHD-00039	EHD-00039
40	HH TAP BOLT,3/8-16 X 4",G2,PLT	EHD-00040	F108560
41	PIPE,PLASTIC,3/4" X 15/16"L	EHD-00041	EHD-00041
42	SPROCKET,IDLER,7 TOOTH	EHD-00042	AG2422
43	CHAIN W/RAISED LINK,BALE,#62,1'	EHD-00043	HC621
44	LINK,BALE ELEV #62 RAISED	EHD-00044	HB4-62
45	IDLER L/PARTS BOX,EHD ELEV,12'	EHD-00045	EHD-121-LPB
46	DECAL,WARNING-BEFORE STARTING	EHD-00046	11096
48	DECAL,DANGER-SHIELDS ARE OFF	EHD-00048	11097
49	RETURN,BALE ELEV #62 CHAIN	EHD-00049	EHD-00049
50	U-BOLT,5/16-18 X 1-3/8 X 2-3/16",G2	EHD-00050	F105020
51	WA,SAE FL,5/8",PLT	EHD-00051	F807070
53	MANUAL ASSY,EHD BALE ELEV OWNER	EHD-00052	EHD-00052
54	DECAL,DANGER-FALLING HAY....	EHD-00053	DEC101293

* Specify serial number of elevator